

Oil-injected screw compressor stage

EU18(II) Series

Air end data

power consumption at driving

shaft recommended [kW]	18
------------------------	----

volume flow max. [m ³ /min]	4.63
--	------

discharge pressure max. [bar a]	15
---------------------------------	----

male rotor speed max. [rpm]	6950
-----------------------------	------

lobe combination	5/6
------------------	-----



Oil-injected screw compressor stage

EU18(II)

Installation drawing [mm]

weight [kg]

40.8

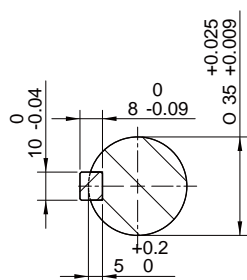

SECTION A-A
1:2

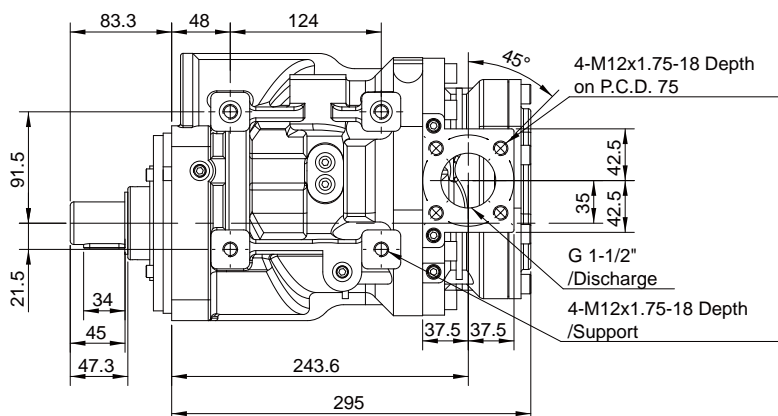
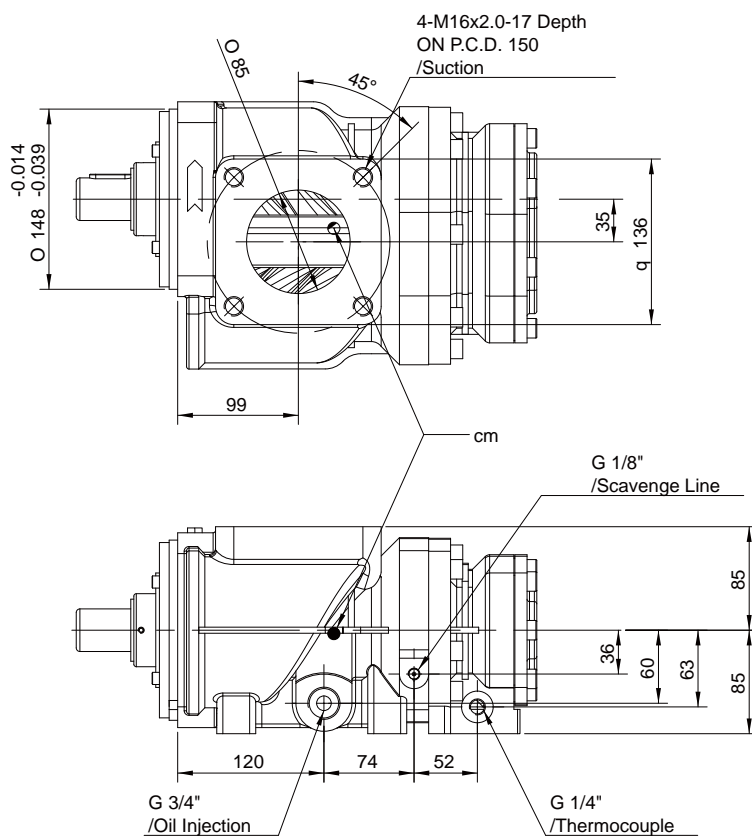
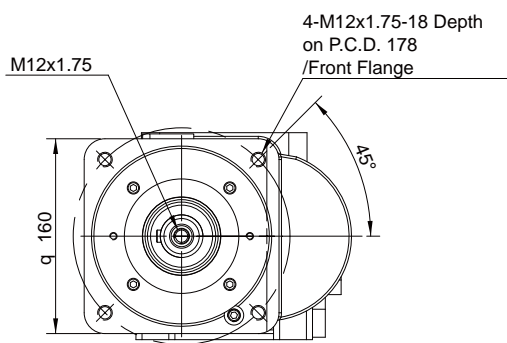

Oil-injected screw compressor stage

EU18(II) Series



Performance data

Performance statements according to ISO 1217

