

Oil-injected screw compressor stage

EU 110 Series

Air end data

power consumption at driving shaft recommended [kW]	110
volume flow max [m ³ /min]	21.7
discharge pressure max. [bar a]	16
male rotor speed max. [rpm]	3,150
lobe combination	5/6

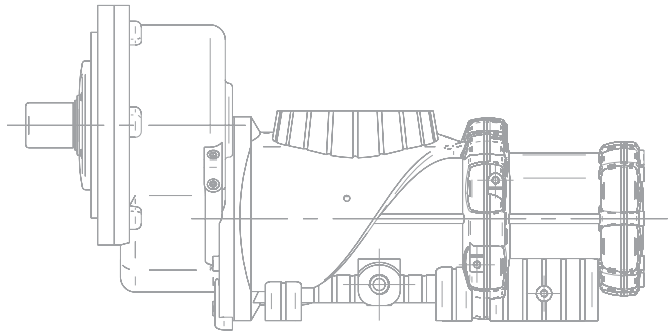
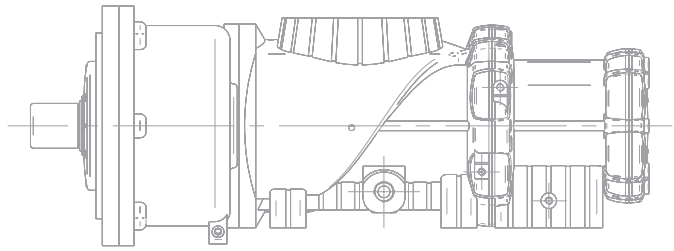

EU 110 Series

Performance data

Performance statements according to ISO 1217

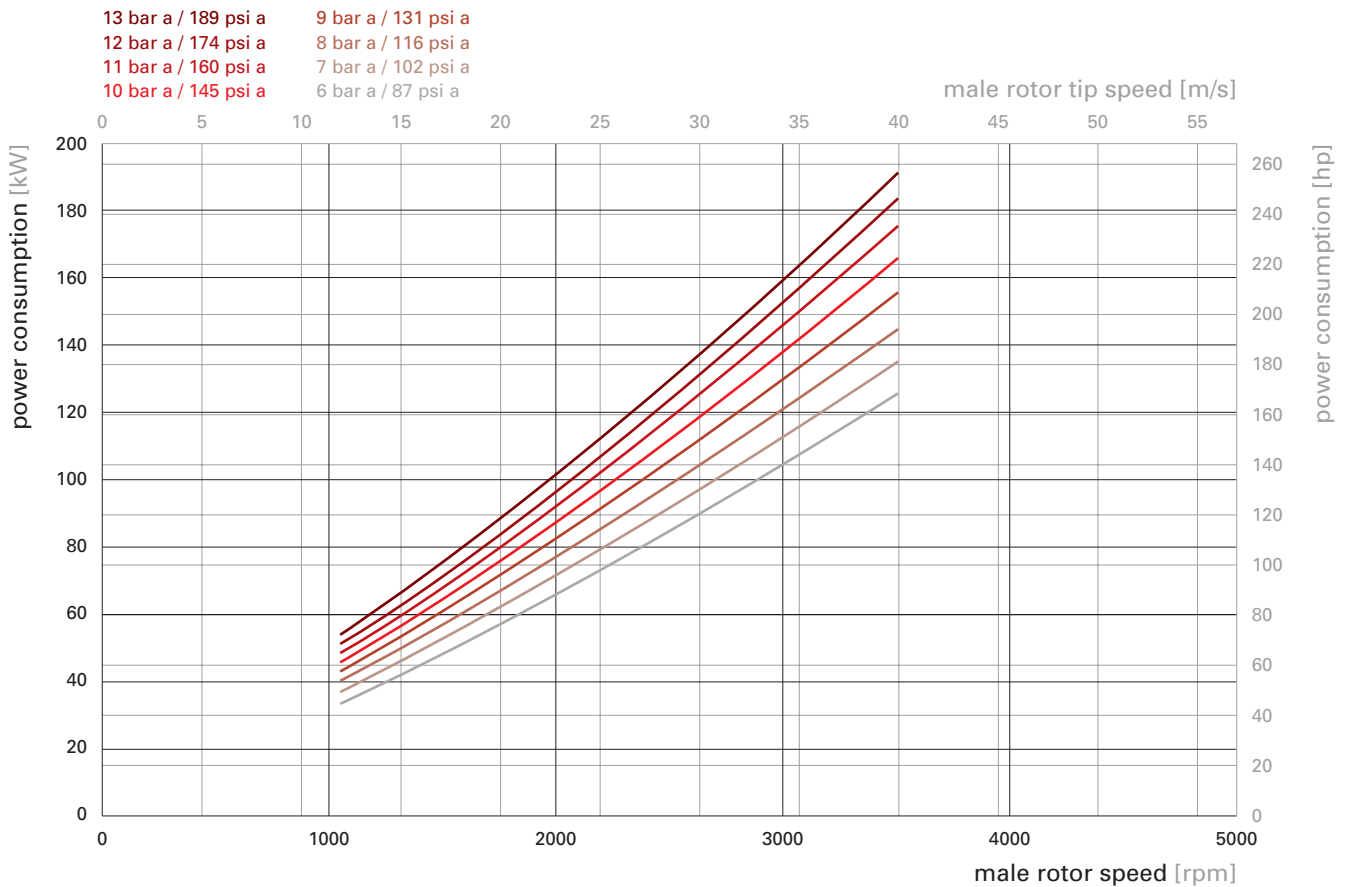
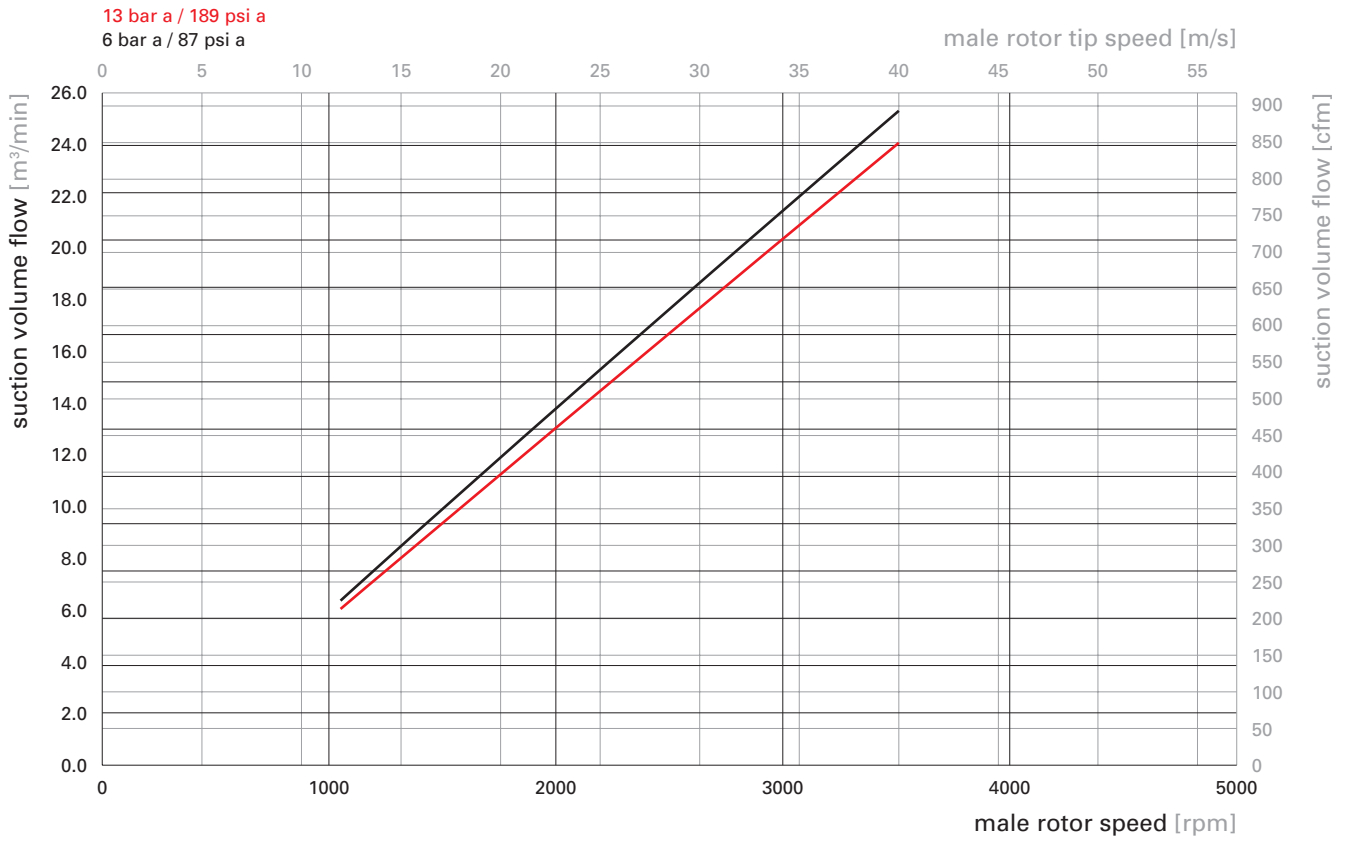

EU 110

Installation drawing [mm]

weight [kg]

337

