

Oil-injected screw compressor stage

EU110(II) Series

Air end data

power consumption at driving

shaft recommended [kW]	110
------------------------	-----

volume flow max. [m ³ /min]	23.08
--	-------

discharge pressure max. [bar a]	15
---------------------------------	----

male rotor speed max. [rpm]	3159
-----------------------------	------

lobe combination	5/6
------------------	-----



Oil-injected screw compressor stage

EU110(II)

Installation drawing [mm]

weight [kg]

374

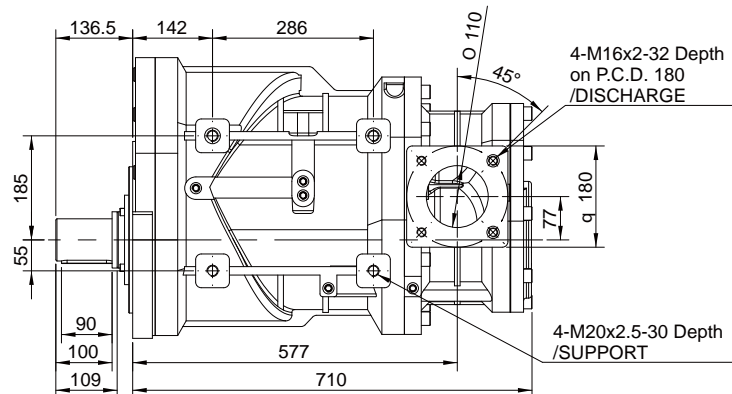
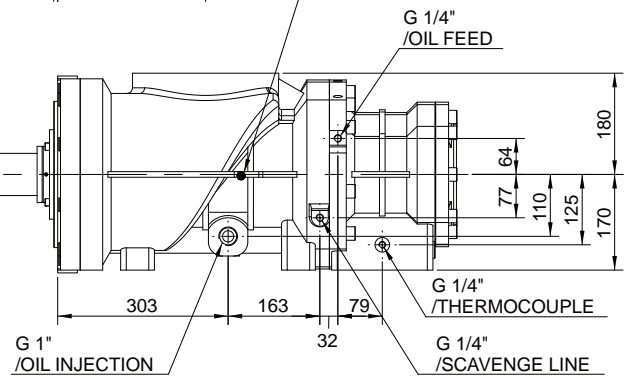
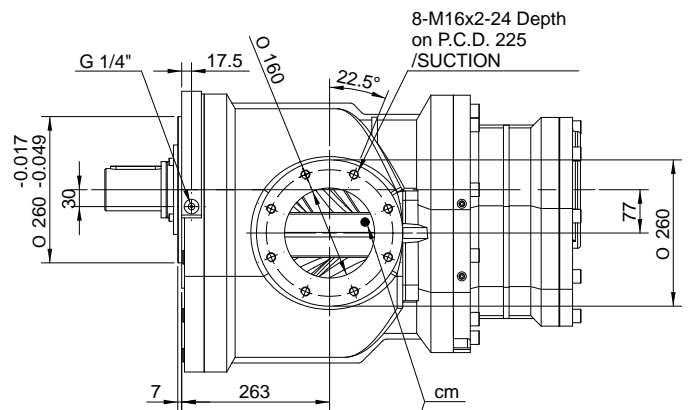
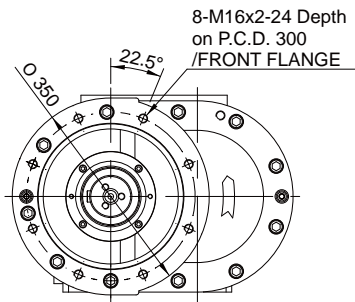
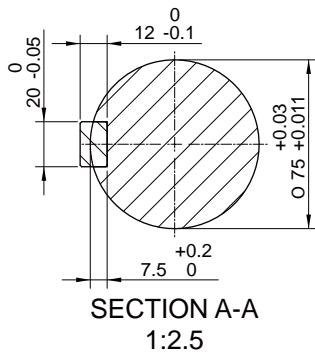

Oil-injected screw compressor stage

EU110(II) Series

Performance data

Performance statements according to ISO 1217

