

Oil-injected screw compressor stage

EU 45(III) Series

Air end data

power consumption at

driving shaft recommended [kW] 45

volume flow max [m³/min] 8.32

discharge pressure max. [bar a] 15

male rotor speed max. [rpm] 5,015

lobe combination 4/5

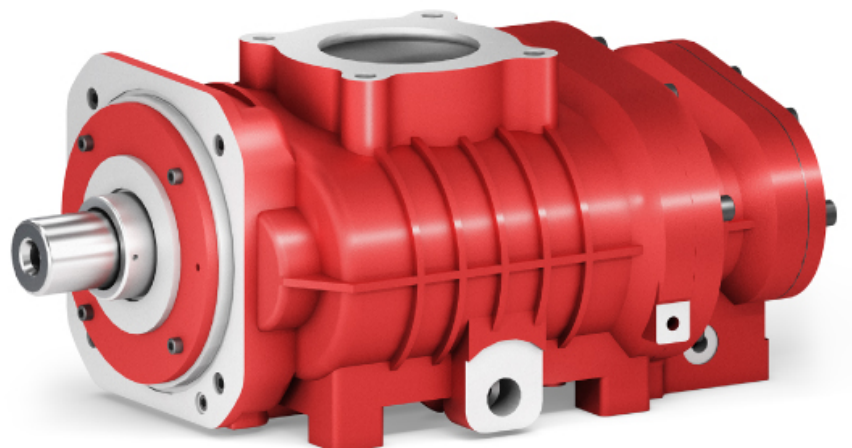
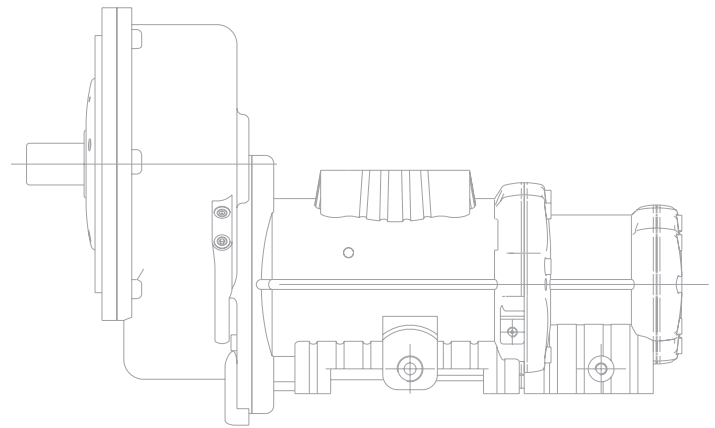
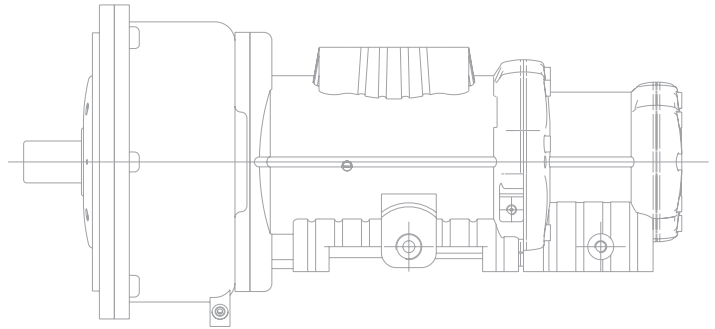

EU 45(III) Series

Performance data

Oil injected screw compressor air end EU45(III)

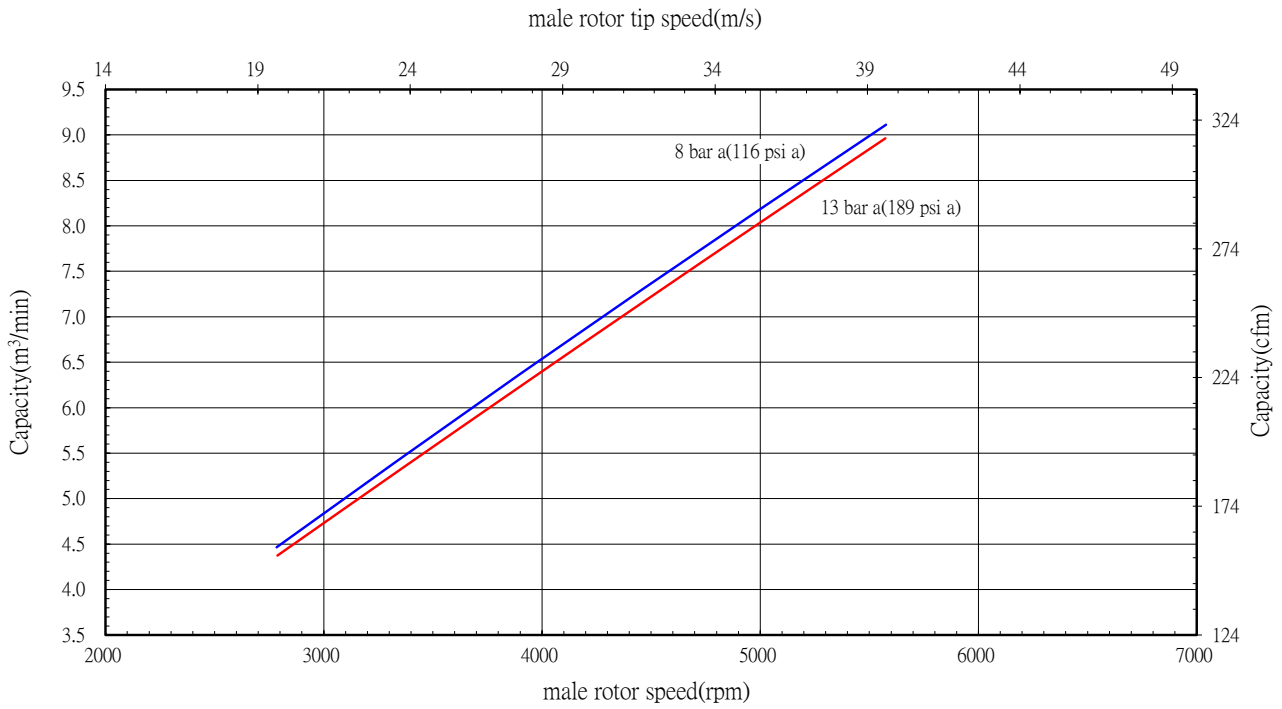

Oil injected screw compressor air end EU45(III)

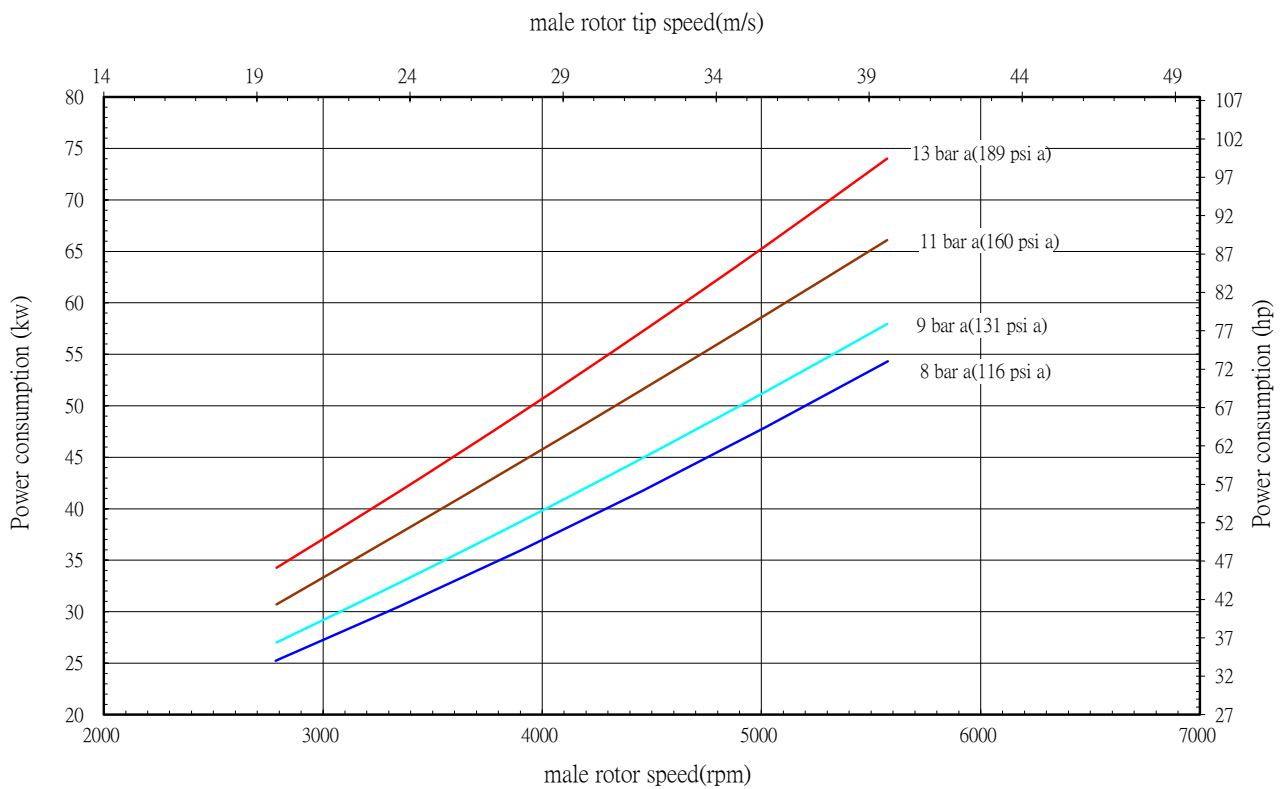

Oil-injected screw compressor stage

EU 45(III)

Installation drawing [mm]

weight [kg]

87.9

