

Oil-injected screw compressor stage

EU 30 Series

Air end data

power consumption at

driving shaft recommended [kW] 30

volume flow max [m³/min] 6

discharge pressure max. [bar a] 16

male rotor speed max. [rpm] 6,500

lobe combination 5/6

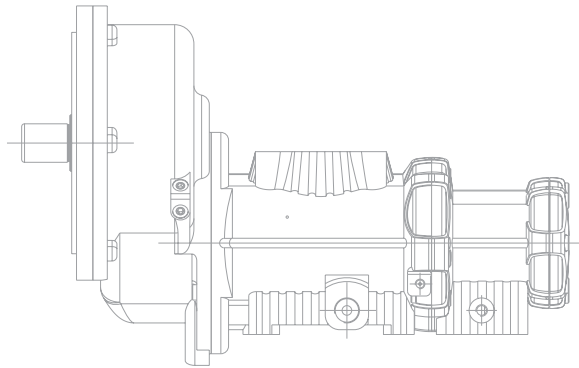
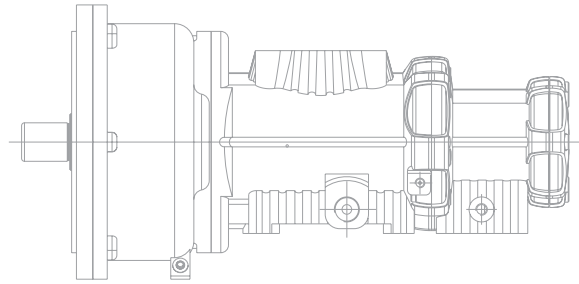

EU30 Series

Performance data

Performance statements according to ISO 1217

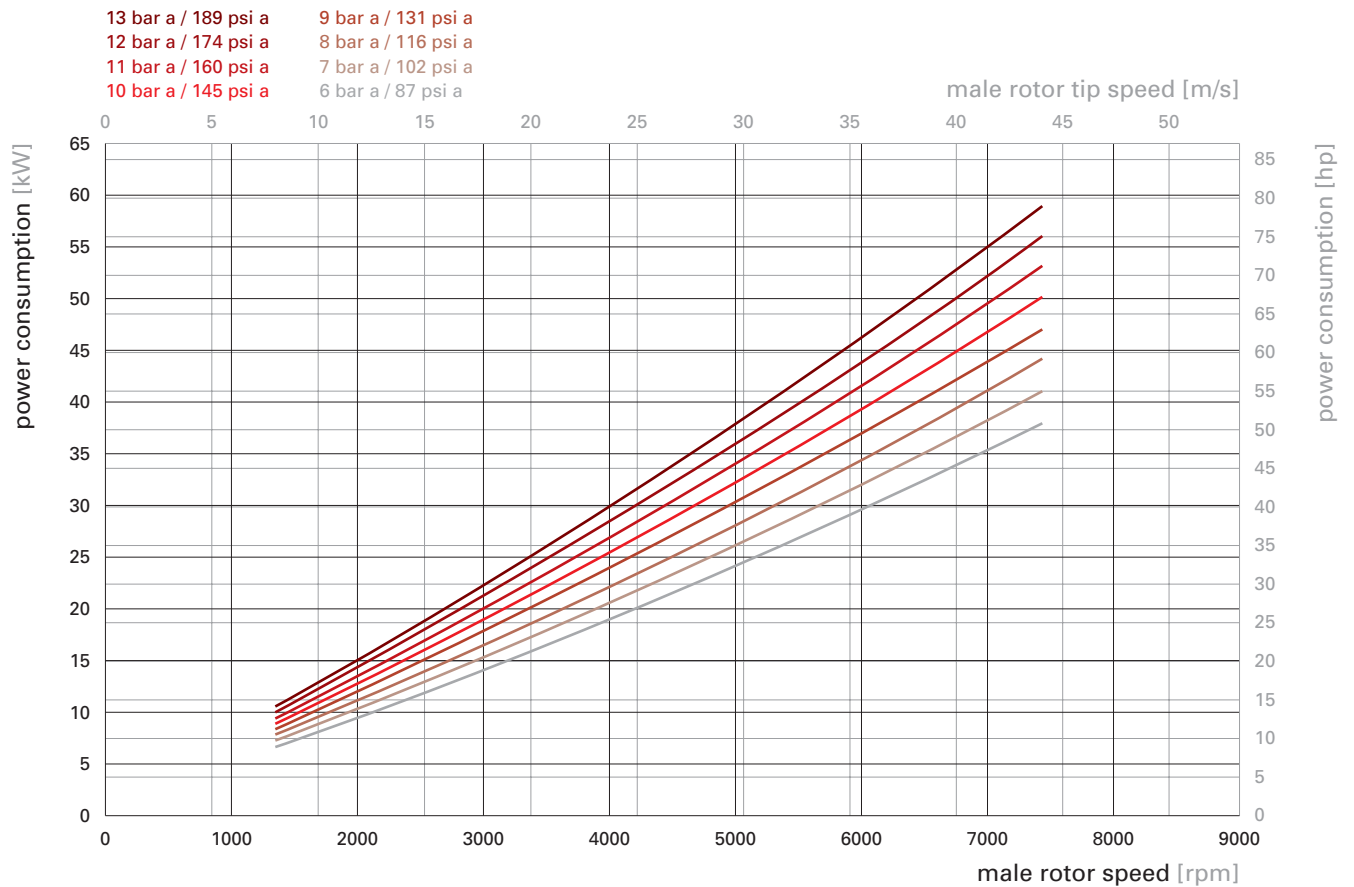
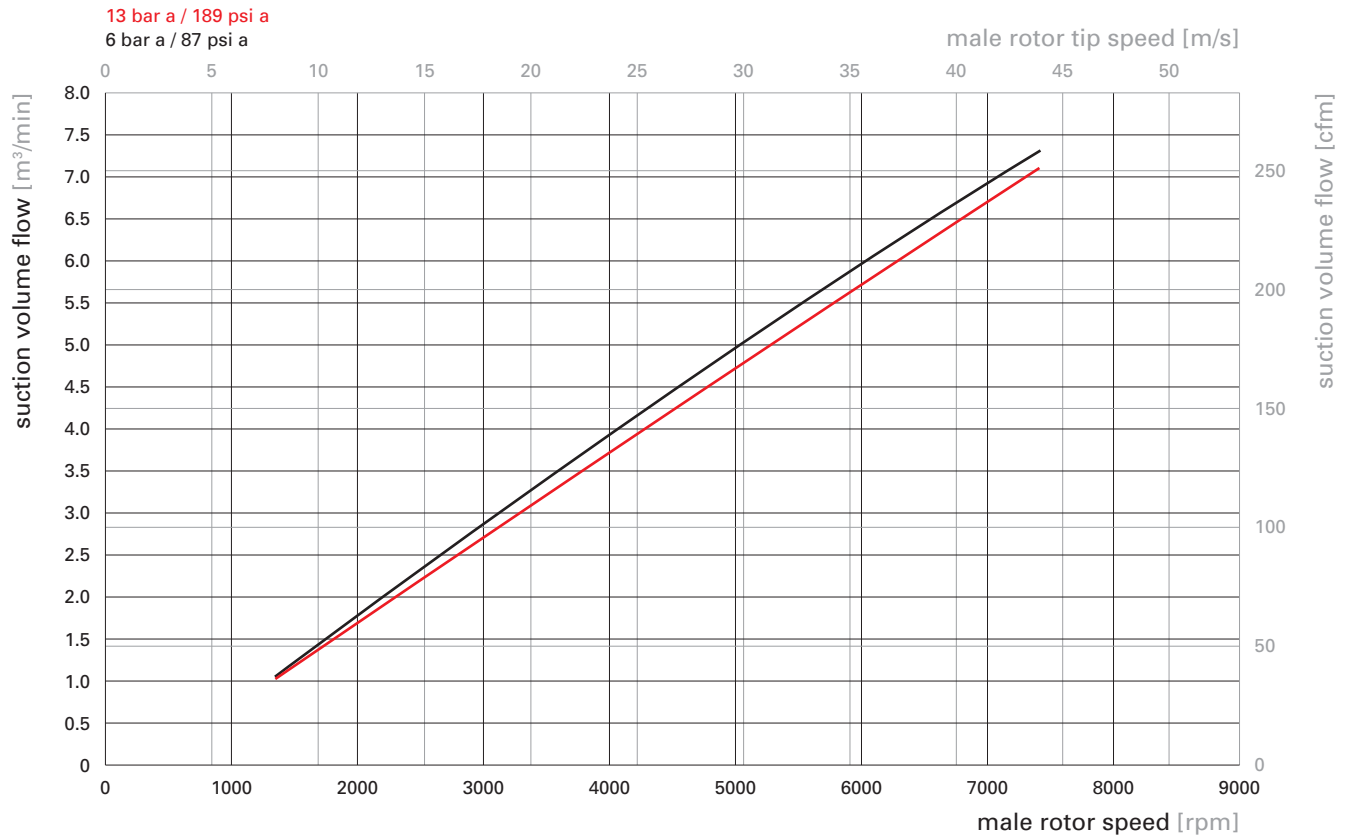

Oil-injected screw compressor stage

EU 30 GV

Installation drawing [mm]

weight [kg]

88.8

